

ECEN 667

Power System Stability

Lecture 10: Wind and Solar Plant Models

Prof. Adam Birchfield

Dept. of Electrical and Computer Engineering

Texas A&M University

abirchfield@tamu.edu



TEXAS A&M
UNIVERSITY

Announcements



- Homework Assignment #3 is online – do not need to turn in but please complete before the first exam.
- Exam 1 in class Thursday, October 9th
- Review the slides and PowerWorld examples

ERCOT Installed Capacity as of Nov 2025



Keep in mind capacity ≠ actual supply ≠ peak conditions

This half is NOT synchronous machine based

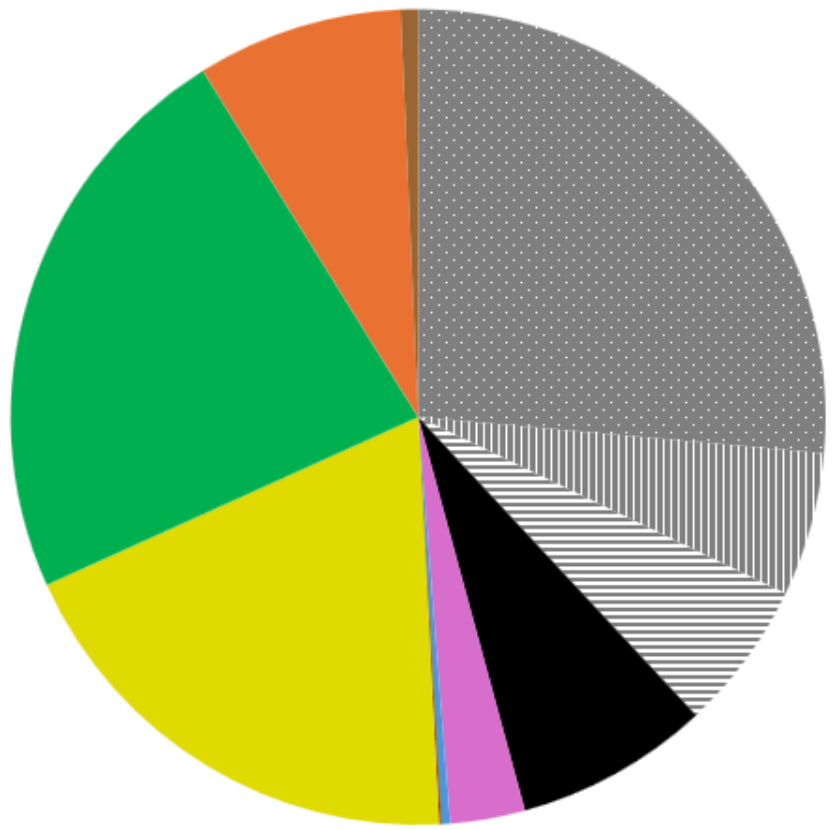

This half is synchronous machine based

- Natural Gas - Combined Cycle
- ▨ Natural Gas - Steam
- ≡ Natural Gas - Gas Turbine
- Coal
- Nuclear
- Hydro
- Diesel
- Biomass
- Solar
- Wind
- Batteries
- DC Tie Net Imports

Getting Power from the Wind



Mechanical power output:

$$P_m = \frac{1}{2} \rho v_w^3 \pi r^2 C_p(\lambda)$$

- ρ is the air density
- v_w is the wind velocity
- r is the blade radius
- $C_p(\lambda)$ is performance coefficient, with λ is the ratio of turbine blade speed to the wind speed
 - Performance is bounded by 59.1% by Betz's Law



Wikimedia commons

General Types of Wind Generators



- For grid stability, we divide wind turbines into four general categories
- Types 1 and 2 are very similar to induction machine models
- Types 3 and 4 have grid dynamics dominated by power electronic converters

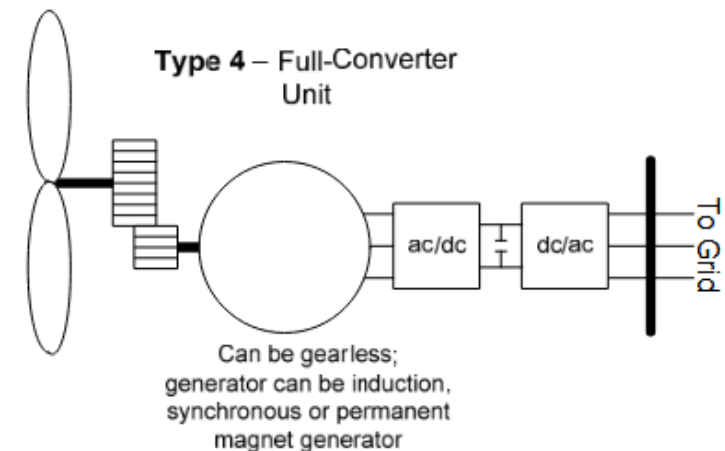
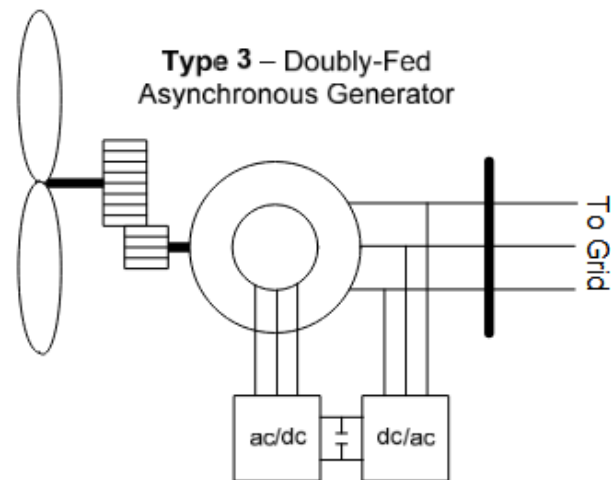
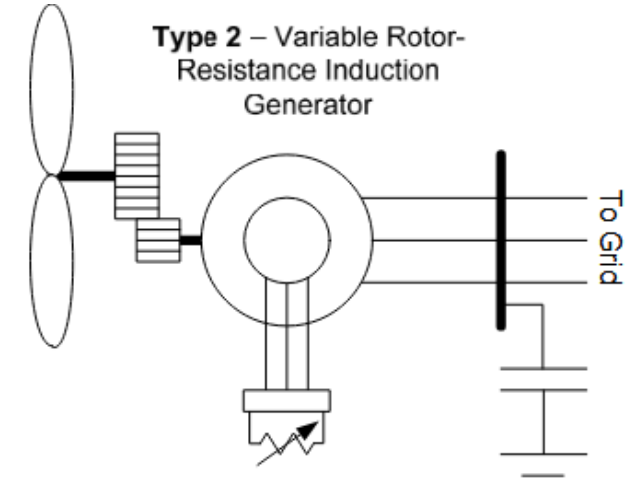
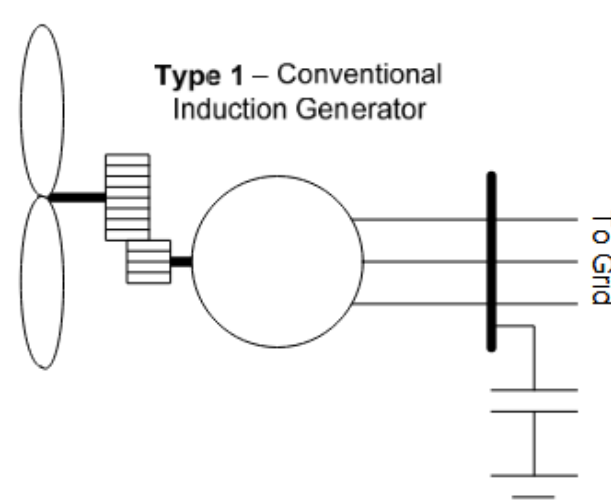

Much material in this section taken from
“WECC Second Generation Wind Turbine
Models” 2014 report

Wind Turbine Type 1



- Type 1 is a conventional induction machine model
- The only control is the pitch angle, to try to optimize turbine efficiency and shaft speed
- Reactive power management must be done through a separate capacitor bank

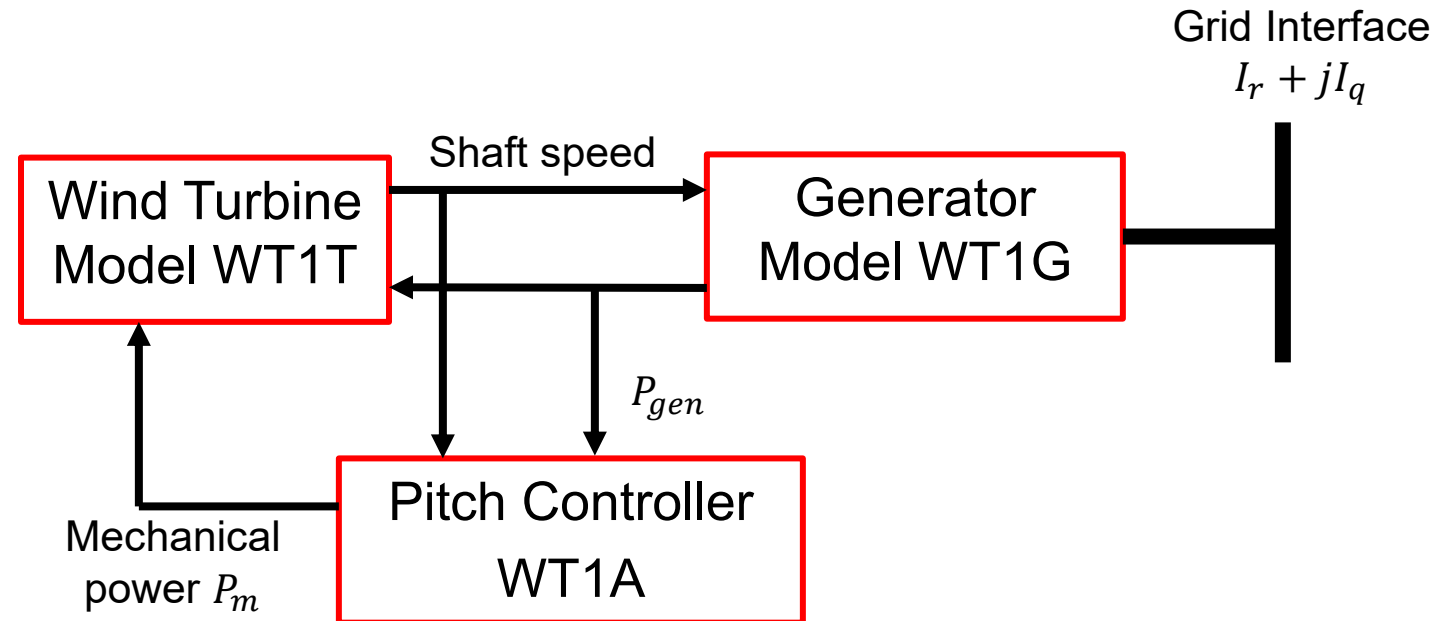

Wind Turbine Type 1, Detailed Model



Wind Turbine (two mass model)

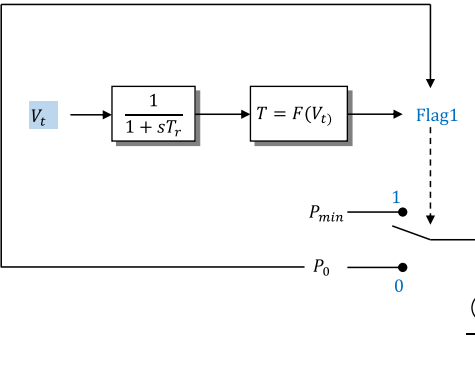
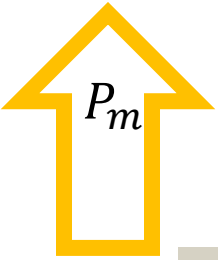
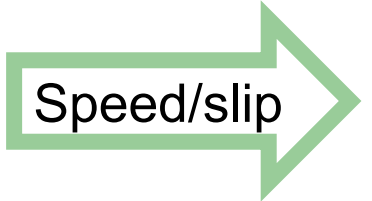
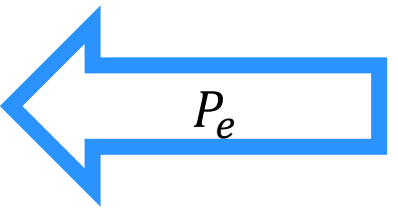
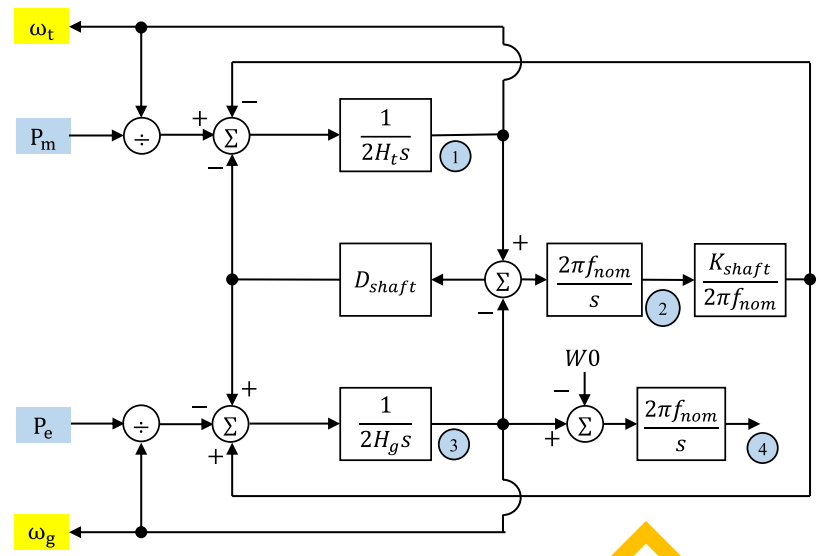

Pitch Controller (simplified)

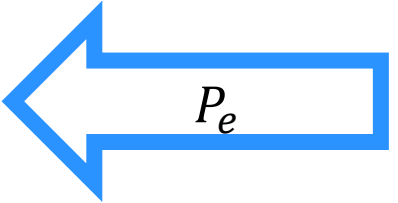

Induction Machine

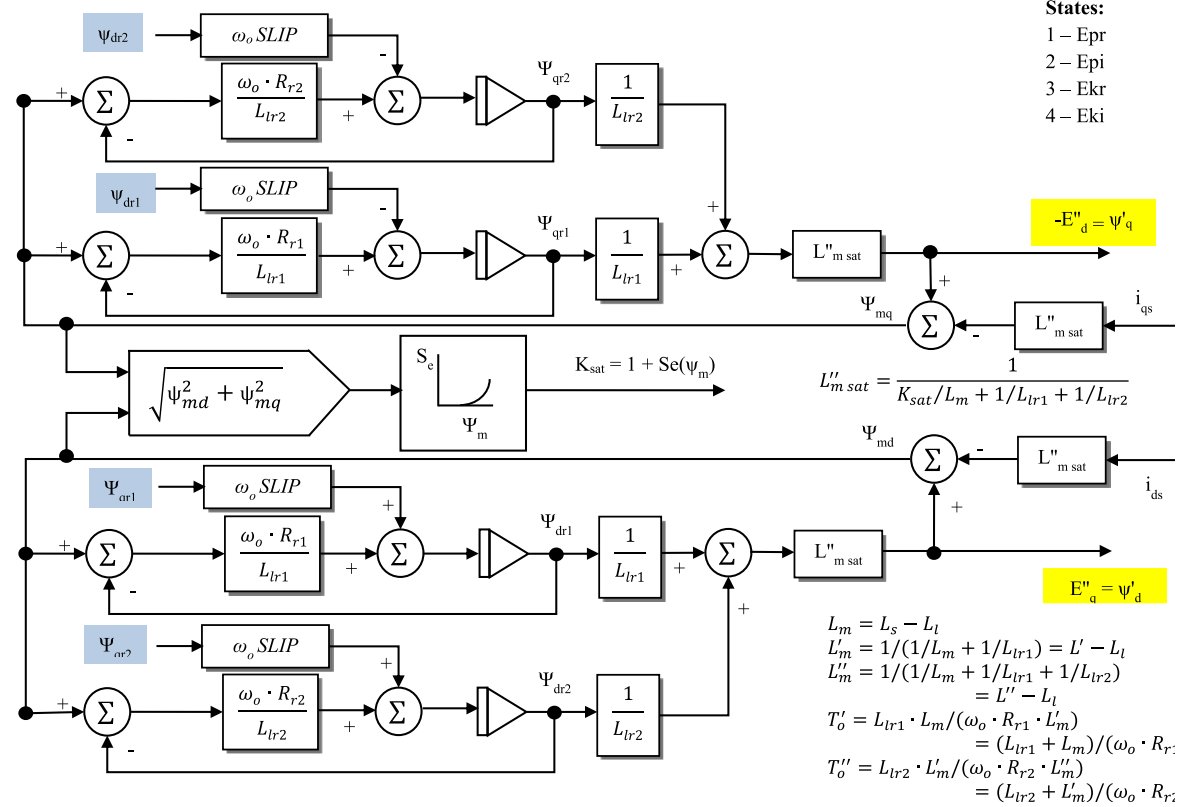

$-E''_d = \Psi'_q$

$E''_q = \Psi'_d$

$L''_m sat = \frac{K_{sat} L_m}{1 + K_{sat} L_m}$

$L''_m = L_s - L_l$
 $L'_m = 1/(1/L_m + 1/L_{lr1}) = L' - L_l$
 $L''_m = 1/(1/L_m + 1/L_{lr1} + 1/L_{lr2}) = L'' - L_l$
 $T'_o = L_{lr1} \cdot L_m / (\omega_o \cdot R_{r1} \cdot L'_m) = (L_{lr1} + L_m) / (\omega_o \cdot R_r)$
 $T''_o = L_{lr2} \cdot L'_m / (\omega_o \cdot R_{r2} \cdot L''_m) = (L_{lr2} + L'_m) / (\omega_o \cdot R_r)$

Wind Turbine Type 2



- Just like Type 1, but also with the ability to control the rotor winding resistance
- This allows a limited variation in speed and somewhat better efficiency
- Reactive power management must still be done through a separate capacitor bank

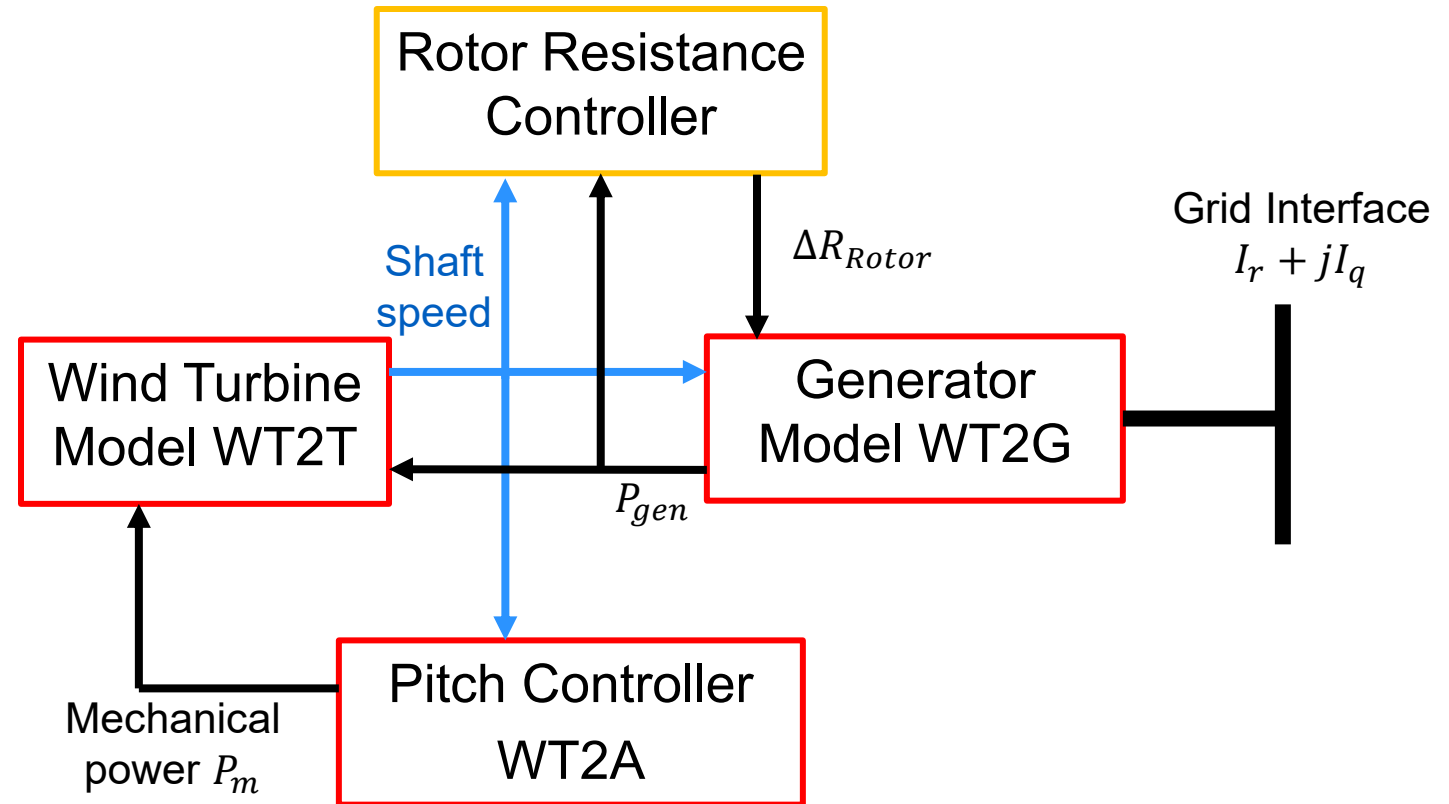

Rotor Resistance Controller for Type 2



- The other 3 model components are very similar to the Type 1 model
- Uses a PI controller to target the optimal resistance within bounds

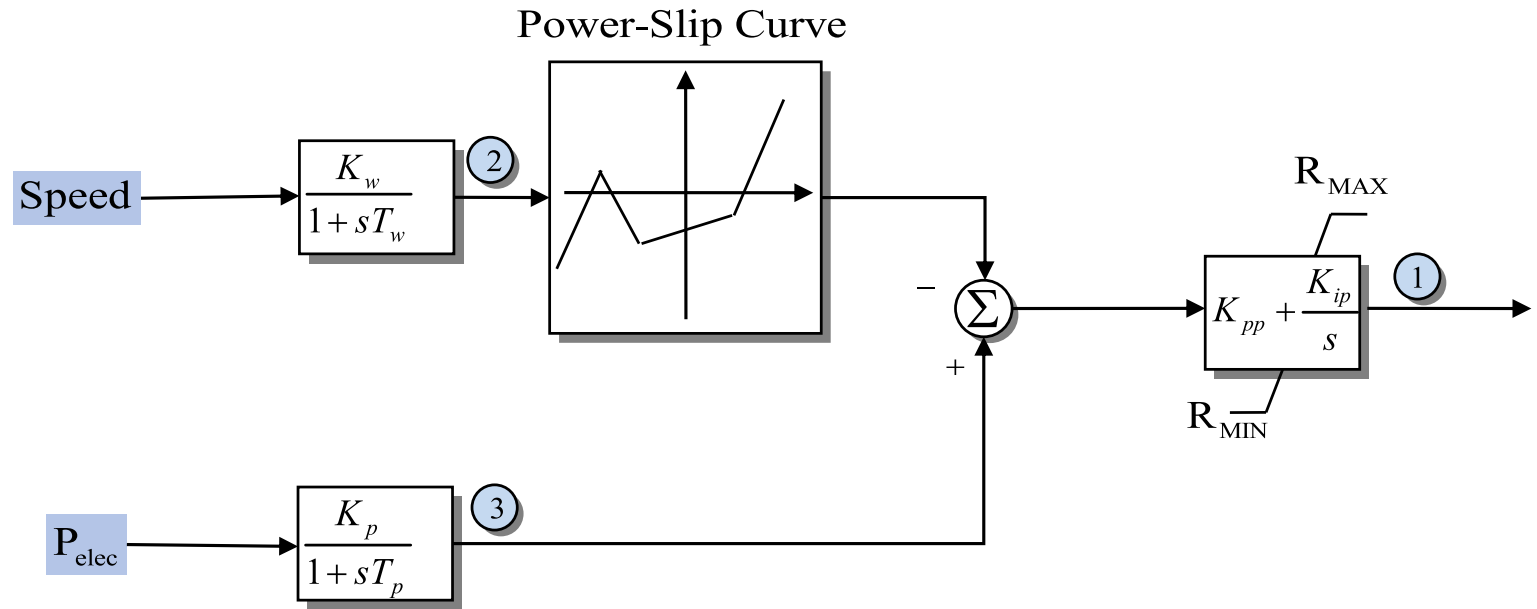

Wind Turbine Type 3



- Still an induction machine, but because of the converters on the rotor windings, it now has control over both P and Q output
- Stator is still directly connected to the grid, so speed is still relevant
- We will go through each of the components next

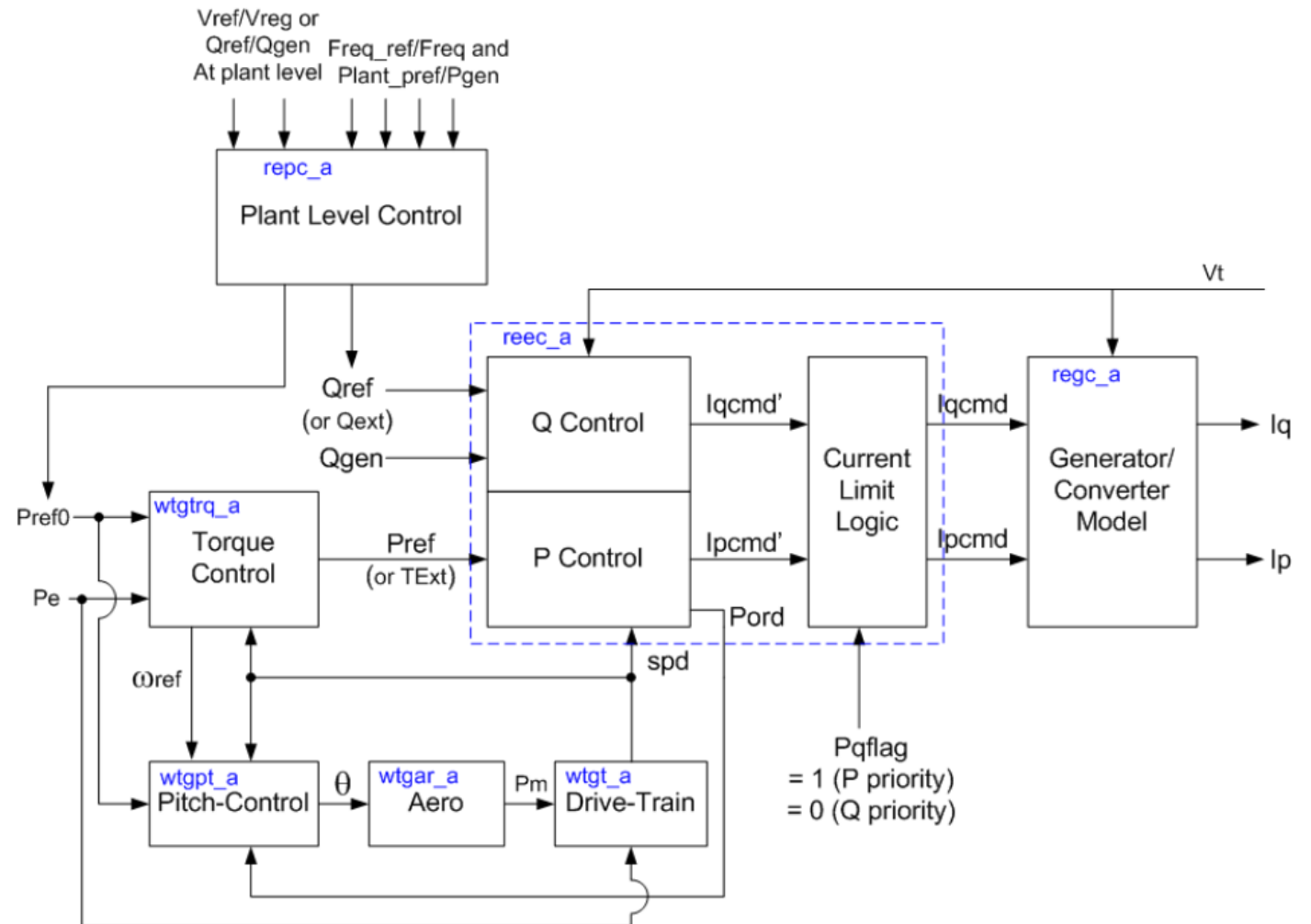

REGC_A for Type 3 Wind



- This is the machine interface for a Type 3 wind turbine
- It is generic to apply also to many converter-interfaced resources (such as Type 4 wind, solar PV, batteries, etc.)
- Basically, it implements a commanded I_p and I_q
- There is High Voltage Reactive Current Management and Low Voltage Active Current Management
- Time delays on voltage measurement, P and Q implementation.

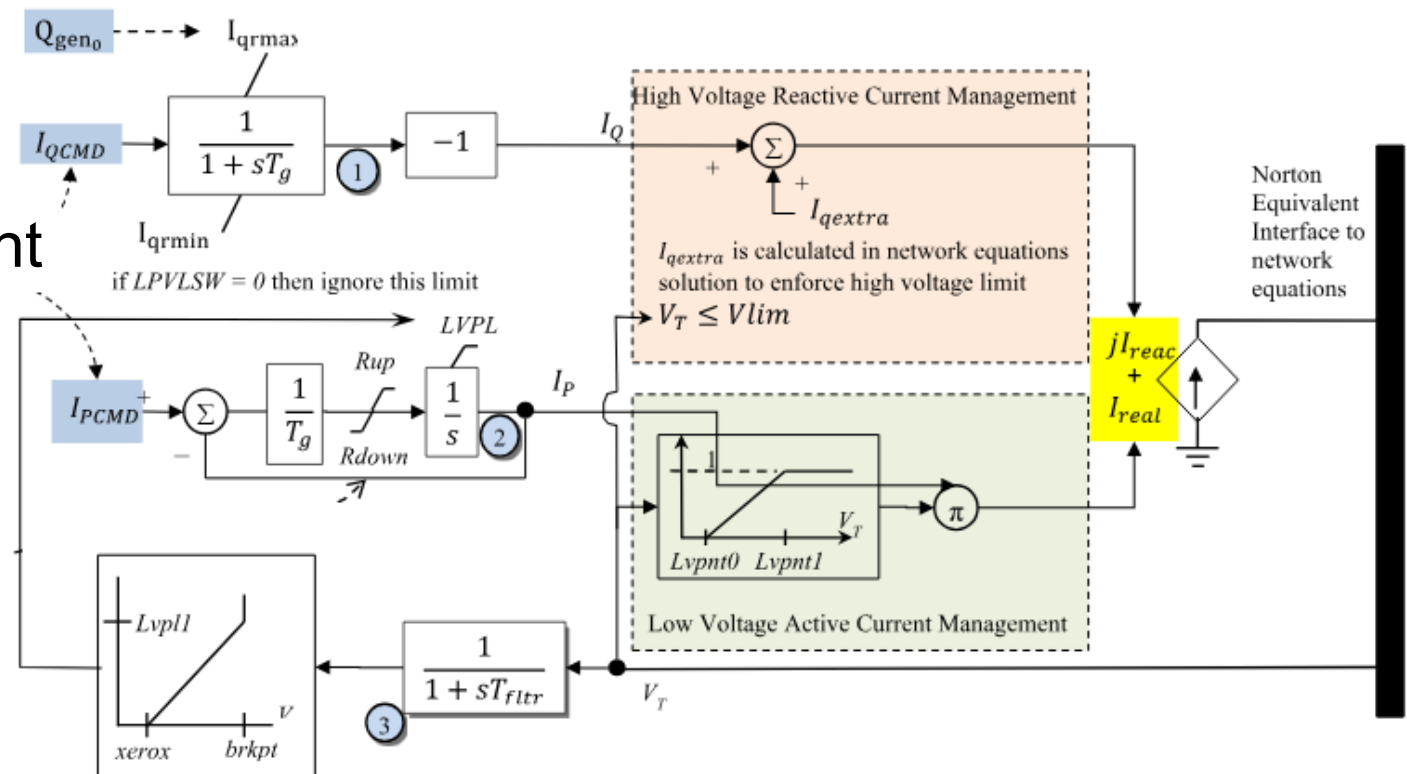

Type 3 Turbine Dynamics and Pitch Control



Torque Control

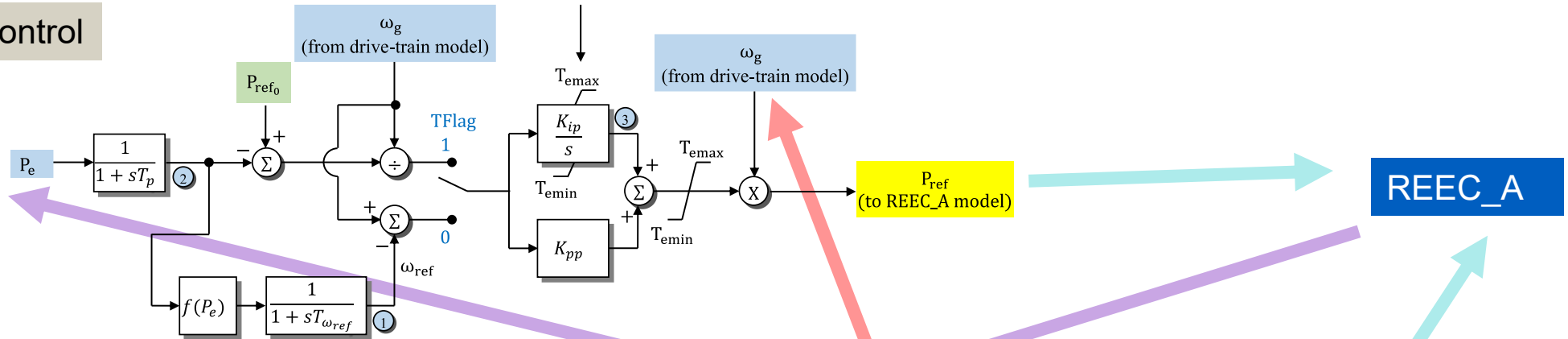

Pitch Controller

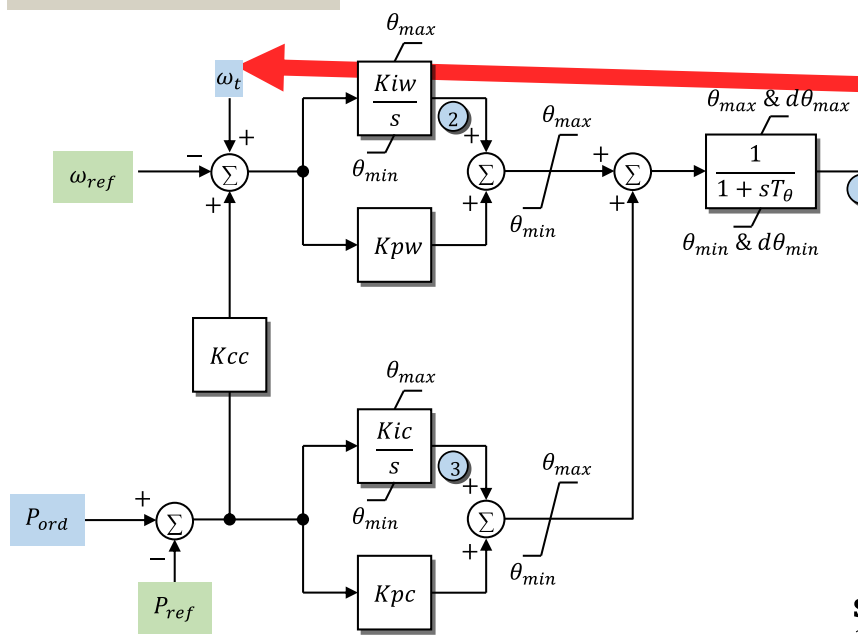

States
1 - Pitch

Aerodynamic Model

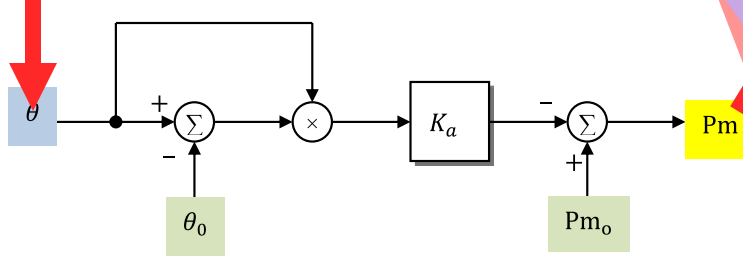

Drive train (two mass)

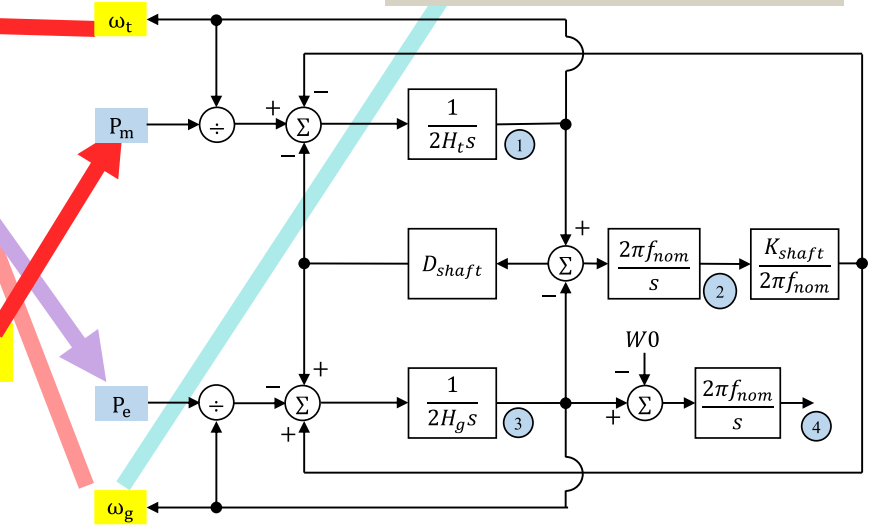

T necessarily represent physical ed; internal model variable)

W0 = initial value of states (1) and (3)

Plant Controller for Type 3 Wind



- Usually, we are not just modeling one wind turbine
- We are modeling an entire plant of dozens of turbines in aggregate
- An optional model for plant control gives the specified P and Q setpoints for the generators, depending on control objectives

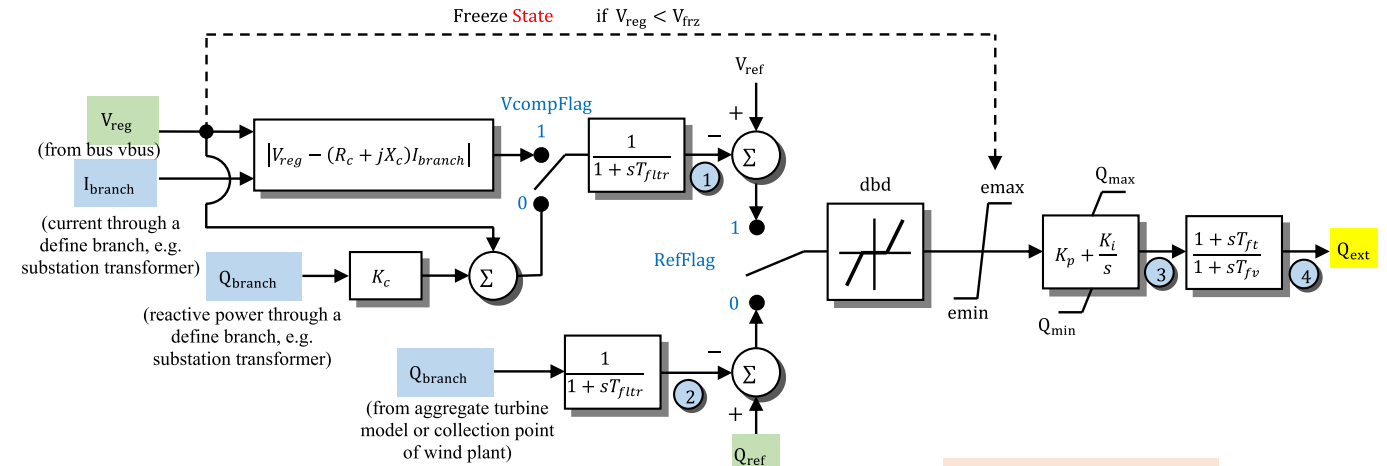

States

- 1 - V_{meas}
- 2 - Q_{meas}
- 3 - Reactive PI
- 4 - Q_{ext}
- 5 - P_{meas}
- 6 - Power PI
- 7 - Pref

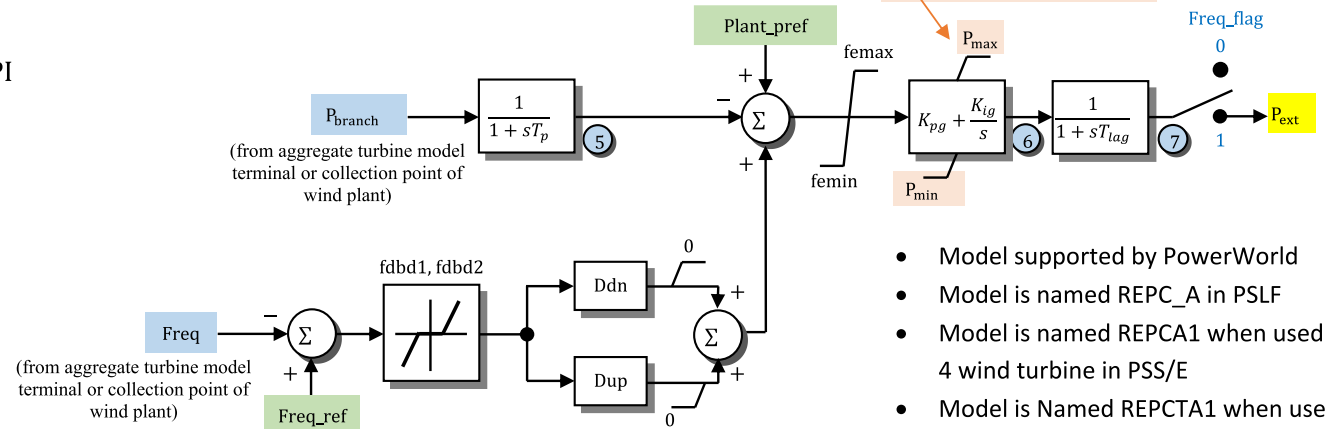

Governor Response Limits setting modifies these limits
Down Only: max limit is set to initial condition value
Fixed: min and max limits are set to the initial condition value

- Model supported by PowerWorld
- Model is named REPC_A in PSLF
- Model is named REPCA1 when used with Type 4 wind turbine in PSS/E
- Model is Named REPCTA1 when used with a Type 3 wind turbine in PSS/E

Wind Turbine Type 4



- Now, full converter model is used
- The physical machine can be either squirrel-cage induction, wound rotor induction, or permanent magnet synchronous machine, but this does not affect the stability model
- Same models as the Type 3 generator, except the drive train components are not usually necessary

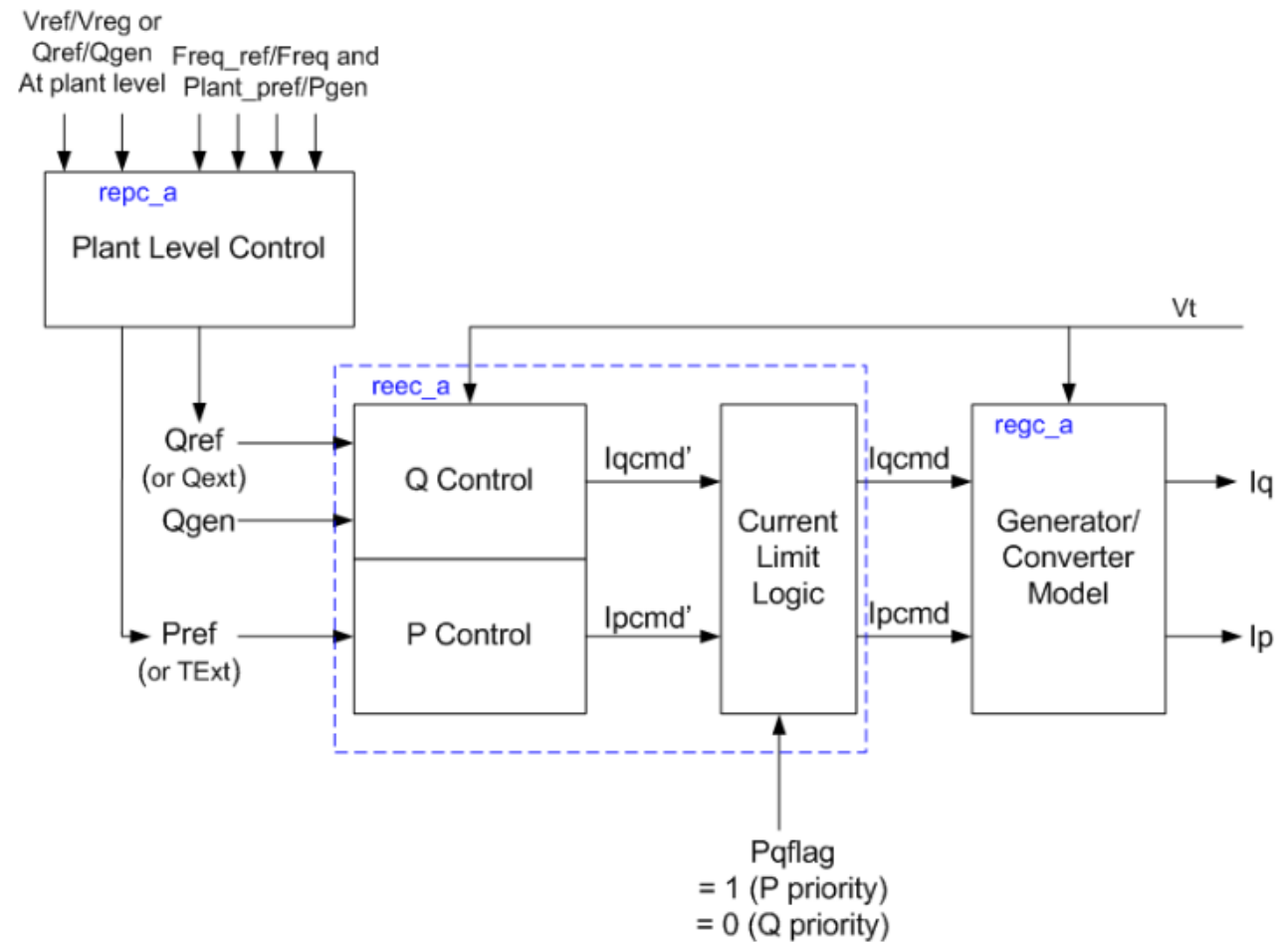

Solar Power (PV)



- Photovoltaic (PV) solar plants take advantage of the photoelectric effect to generate a dc current across a semiconductor in the presence of sunlight
- That dc power must be converted to ac for grid interface by the use of a power electronic based inverter



Solar PV Plant Generic Model



- We can use a nearly identical model type to a Type 4 Wind plant, as both types use a full converter interface
- Parameters will be different

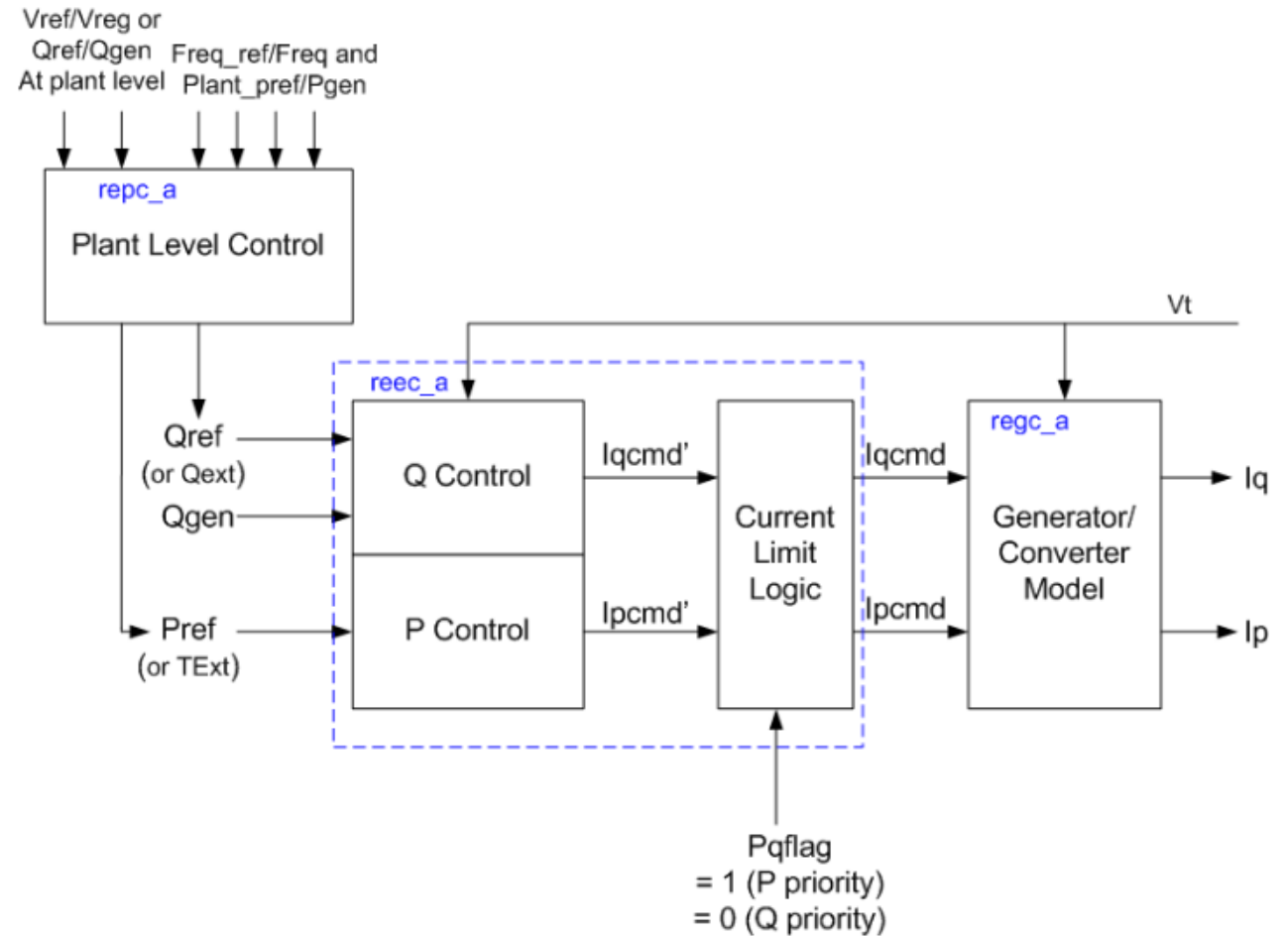

Example for Converter Initialization



- Assume a Type 4 wind turbine plant is producing 88 MW and 15 Mvar (100 MVA base), and the terminal voltage is 1.03 per-unit. Use the following models:
 - REGC_A with parameters LVPLSW=0, rrpwr=10, brkpt=0.9, zerox=0.5, LVPL1=1.22, Vlim=1.2, LVPnt1=0.8, LVpnt0=0.4, Tg=0.02, Tfltr=0.02, Iqrmax=0, Iqrmin=0, Qmin=-1.3, Khv=0.7, Xe=0 (Ignore the “current management” blocks and the LVPL1 block)
 - REEC_A with parameters PfFlag=0, VFlag=1, QFlag=1, Pqflag=0, Pflag=0, Vdip=0.85, Vup=1.15, Trv=0.02, dbd1=0, dbd2=0, kqv=0, Iqh1=1.1, Iql1=-1.1, Vref0=0, Iqfrz=0, Thld=0, Thld2=0.5, Tp=0.02 Qmax=0.436, Qmin=-0.436, Vmax=1.1, Vmin=0.9, Kqp=0, Kqi=0.4, Kvp=11.4, Kvi=3.8, Vref1=0, Tiq=0.02, dPmax=99, dPmin=-99, Pmax=1, Pmin=0, Tpord=0.04, Imax=1.3 (assume you never hit the “freeze state” and ignore the current limit logic)
 - No plant controller
- Draw a simplified combined block diagram for this model, and calculate the initial values of all state variables.

Example for Converter Initialization, Solution

